

Entry Level Automation

Erizo 60/100

The ERIZO is a versatile Loader/Unloader that can serve as a Loader at the beginning of any horizontal production line or as an Unloader at the end of the line.

It offers the flexibility to handle a wide range of horizontal lines, whether the panels are used as inner or outer layers.

When used for Loading/Unloading inner layers, the Erizo requires the installation of metallic bars to support the panels in a vertical position. In such cases, a conveyor

is always necessary when metallic bars are employed. However, when using the Erizo to load or unload rigid panels or outer layers, the panels will smoothly slide into an aluminum profile with a U shape, eliminating the need for metallic bars.

These units are equipped with a user-friendly touch screen interface and a PLC that offers seamless connectivity to the production line to be loaded or unloaded.

There are two versions of the Erizo available: Erizo 60 with a capacity of 60 panels and Erizo 100 with a capacity of 100 panels. The Erizo can be configured with either one or two conveyors, depending on the specific functionality and the needs of the customer.

Erizo 100 + 2 Conveyors



Erizo 100 + 1 Conveyor

Erizo 60 + 2 Conveyors



	Length	Width	Thickness	Weight	Line speed range	
Max. Panel	650mm	530mm	3,4-5mm	- Kg	Panel / min	6
Min. Panel	630mm	530mm	0,8 mm	4Kg	Max m / min	5
					Min m/min	0,5

Youtube
Channel



Entry Level Automation

Erizo 60/100

Technical features

Main features	Unloader	Loader	Buffer
PLC Control	✓	✓	✓
Touch Screen	✓	✓	✓
Input Conveyor	O	O	O
Output Conveyor	O	O	O
Metallic Rods	O	O	O
Buffer configuration	O	N	O
Extended conveyor	O	O	O
Double Sheet Detector	N	O	O

✓ = Included
 O = Optional
 N = Not available

Dimensions

Erizo 100

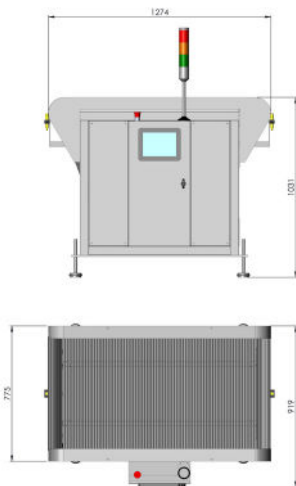

Erizo 100 + Conveyor

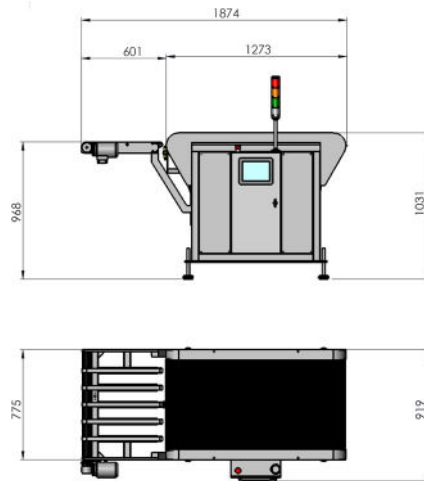

Erizo 100 + 2 Conveyors

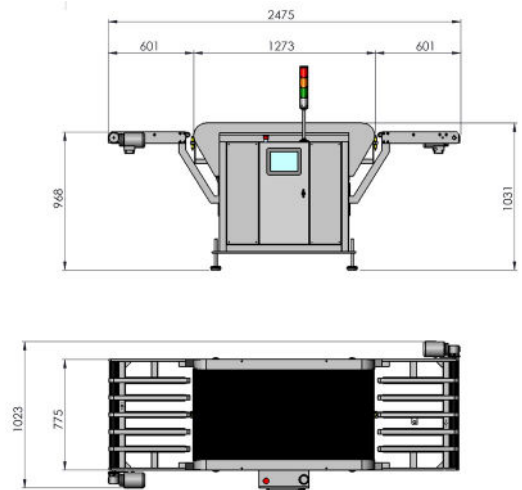

Erizo 60

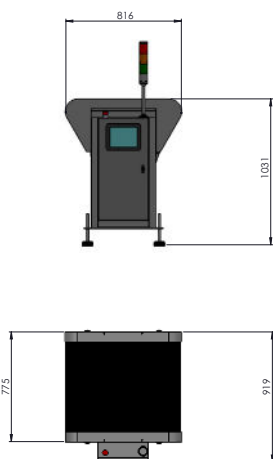

Erizo 60 + Conveyor + Bars

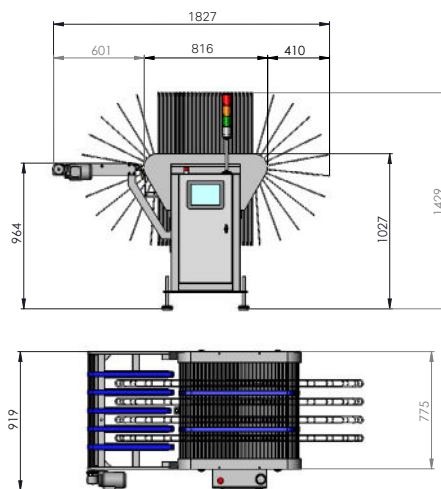

Erizo 60 + 2 Conveyors + Bars

